

Copyright Reserved

The Contractor shall verify and be responsible for all dimensions. DO NOT scale the drawing -- any errors or omissions shall be reported to Stantec without delay.
The Copyrights to all designs and drawings are the property of Stantec. Reproduction or use for any purpose other than that authorized by Stantec is forbidden.

Consultants

Legend

Notes

Revision By Appd. YY.MM.DD

Issued By Appd. YY.MM.DD

File Name: SOIL EROSION-01.DWG TTN DRW DRW 11.02.07

Permit-Seal Dwn. Chkd. Dsgn. YY.MM.DD

Client/Project

ANN ARBOR TOWNSHIP

Standard Specifications and Details

Title

SOIL EROSION DETAILS

Project No. Scale

NOT TO SCALE

Drawing No. Sheet Revision

SE-01 1 of 1 0

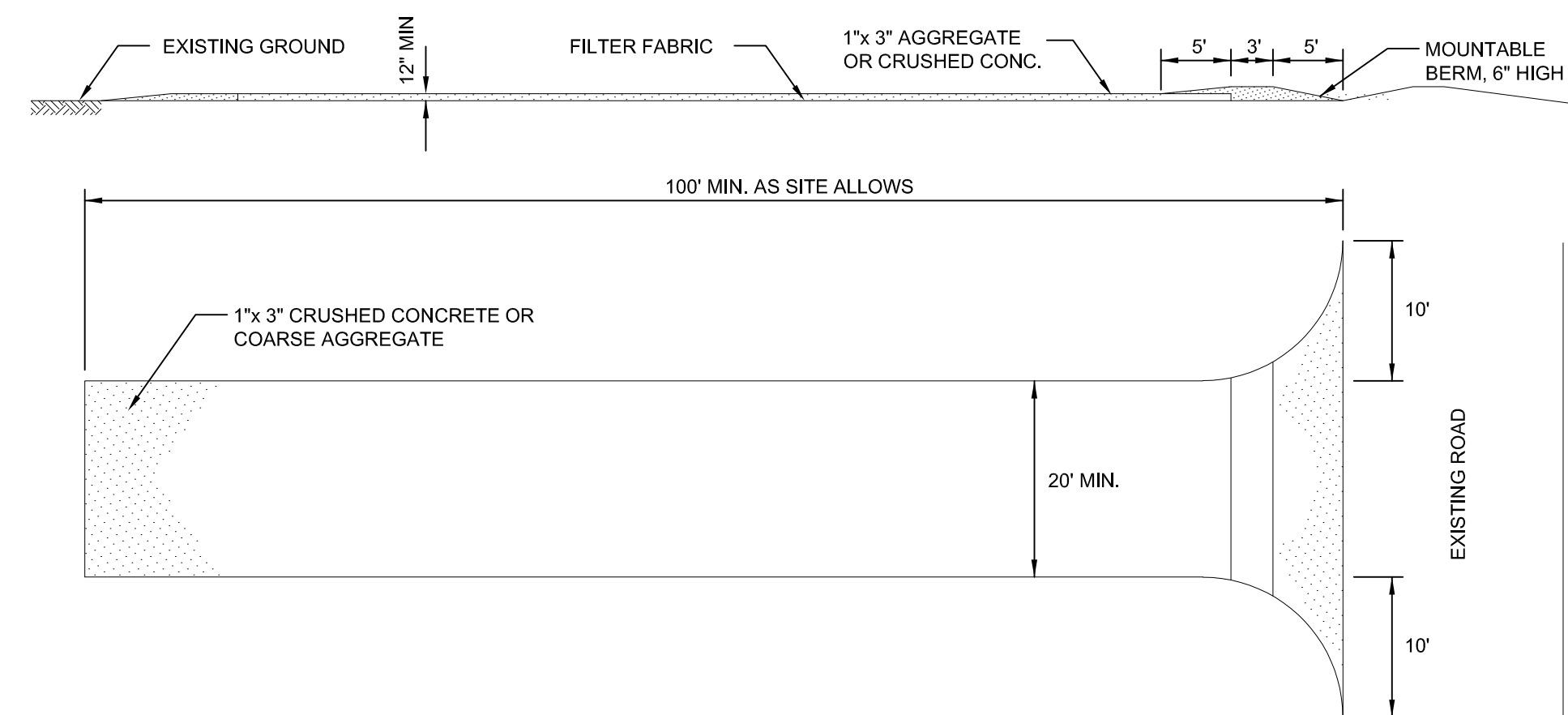

MUD TRACKING ROAD (MUD MAT) DETAIL

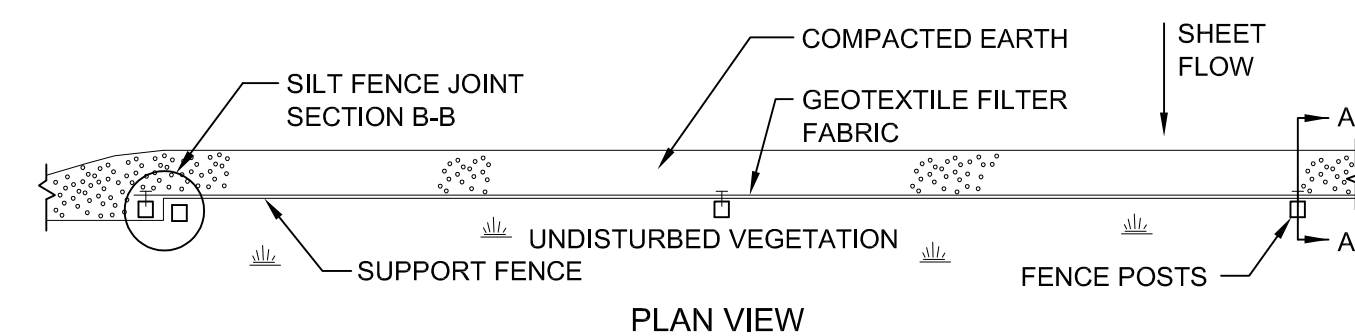

PLAN VIEW

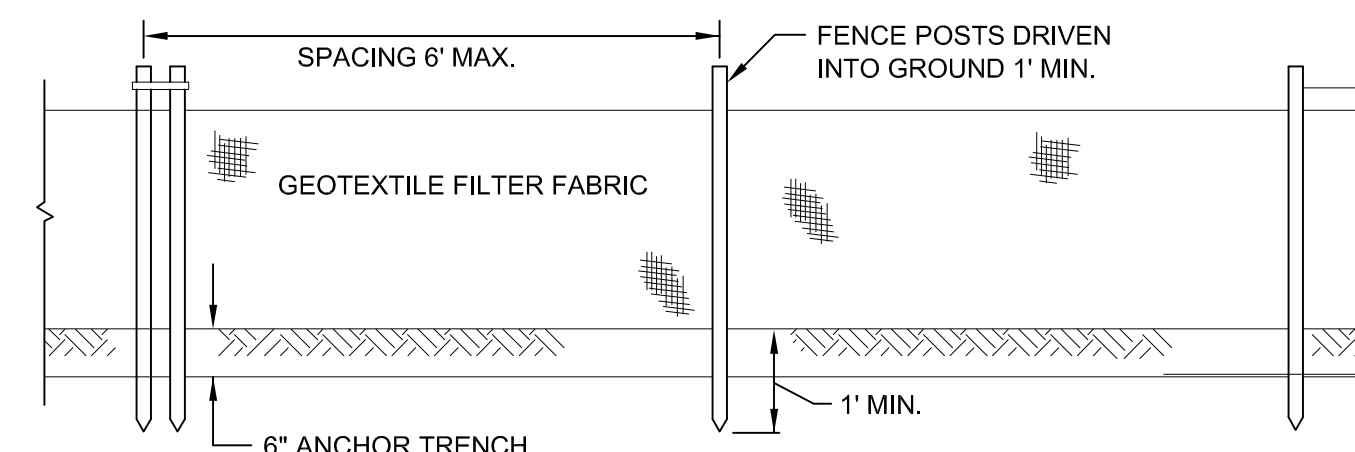

FRONT VIEW

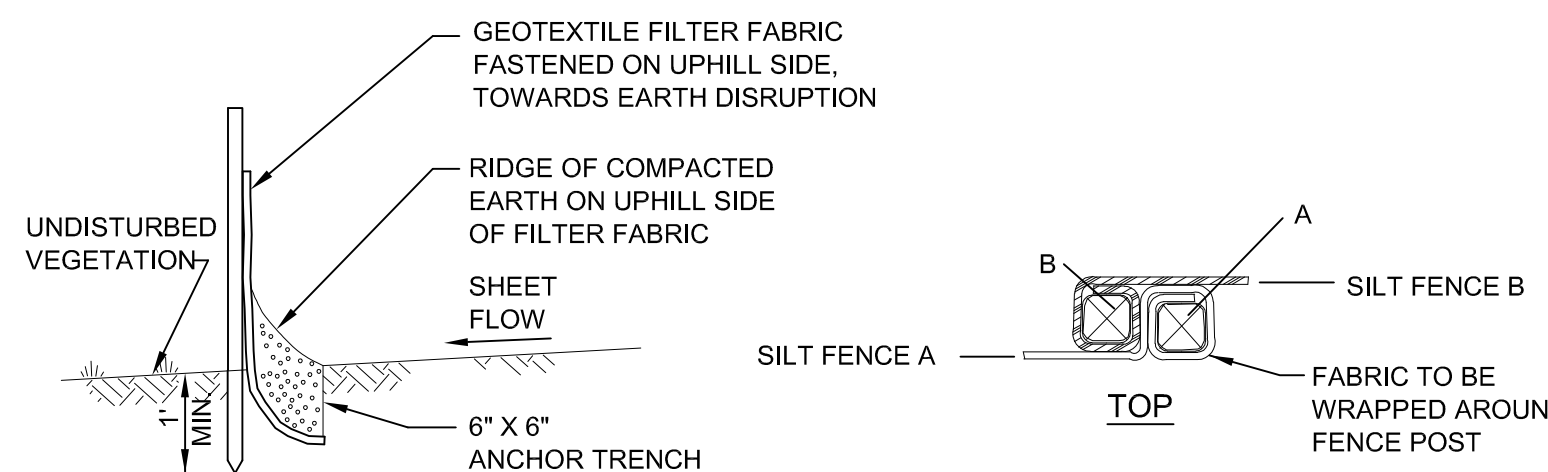

SECTION A-A

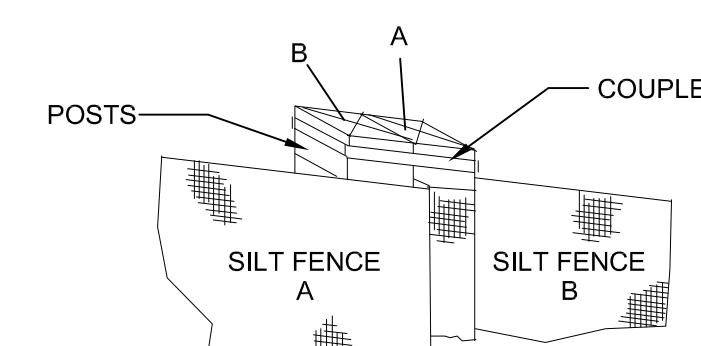

SECTION B-B JOINT

SILT FENCE

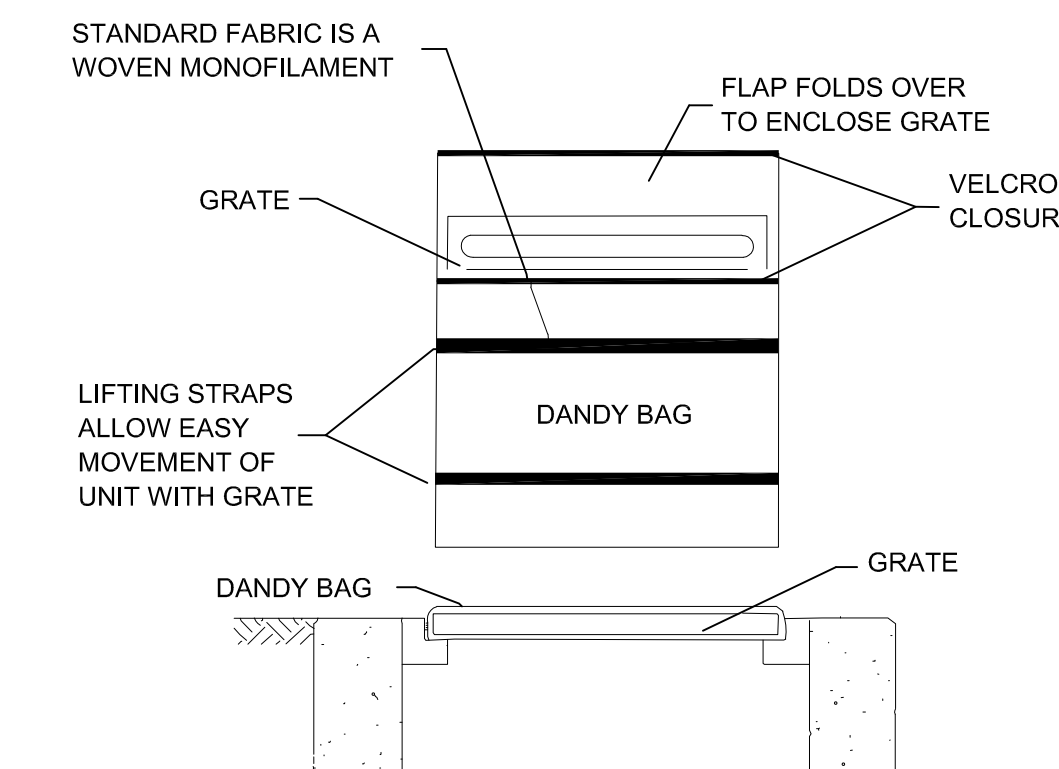

DANDY BAG

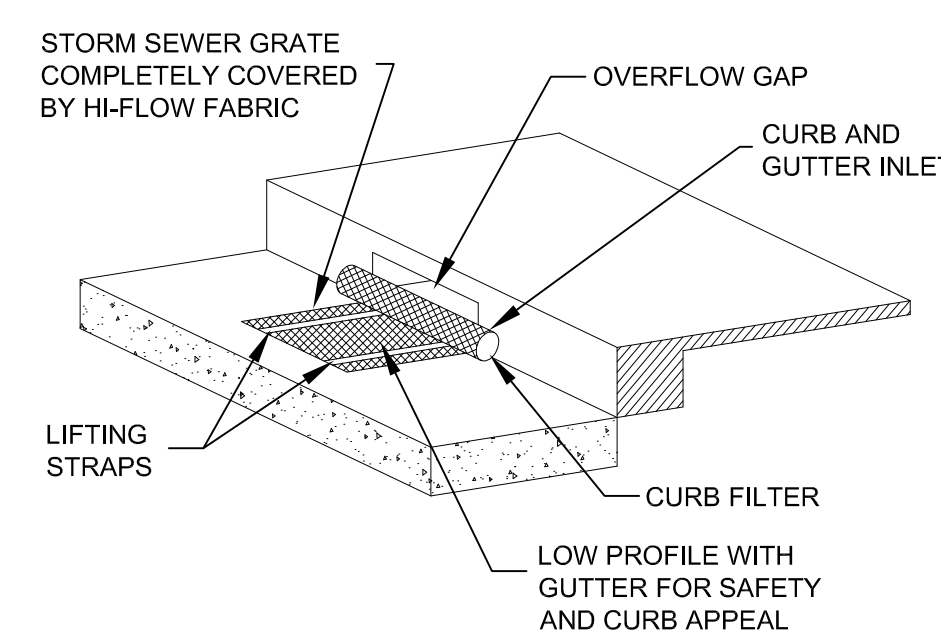

DANDY PRODUCTS - DANDY CURB BAG® (with Curb Filter)

FLAT GRATE AND MOUNTABLE CURB INLET PROTECTION

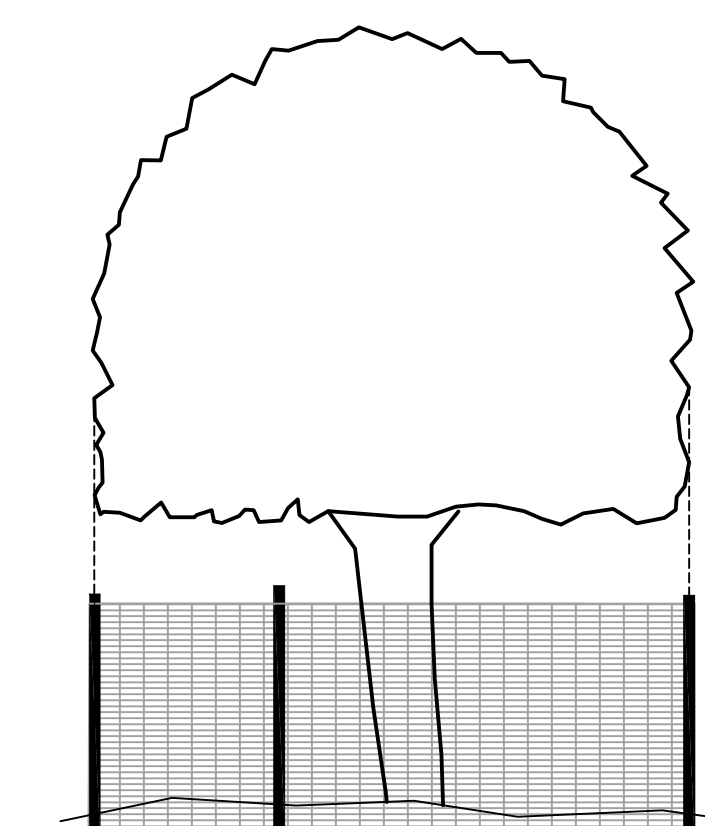

NOTES:

- ALL TREES TO BE REMOVED WILL BE IDENTIFIED BY RED FLAGGING.
- TREE PROTECTION FENCING IS TO BE ERECTED PRIOR TO ANY EARTHWORK OR CONSTRUCTION AND IS TO REMAIN IN PLACE UNTIL CONSTRUCTION AND GRADING IS COMPLETE.
- ALL DEBRIS, FILL, EQUIPMENT OR MATERIAL IS TO BE KEPT CLEAR OF AREA WITHIN PROTECTIVE FENCE. NO CLEANING OF EQUIPMENT OR MATERIAL OR STORAGE OR DISPOSAL OF ANY MATERIAL WITHIN THE DRIP LINE OF ANY TREES TO BE SAVED.

TREE PROTECTION FENCE DETAIL