

Copyright Reserved
 The Contractor shall verify and be responsible for all dimensions. DO NOT SCALE DRAWINGS.
 Standard details are shown for reference only. The Contractor shall verify all dimensions and details. The Contractor shall be responsible for all dimensions and details. The Contractor shall be responsible for all dimensions and details.

Consultants

Legend

Notes

NO.	DATE	BY	CHKD.	APPD.	REVISION
1	11.02.07	MM	ROC	YVM/MD	ISSUED
2	11.02.07	MM	ROC	YVM/MD	UPDATES
3	11.02.07	MM	ROC	YVM/MD	UPDATES
4	11.02.07	MM	ROC	YVM/MD	UPDATES
5	11.02.07	MM	ROC	YVM/MD	UPDATES
6	11.02.07	MM	ROC	YVM/MD	UPDATES
7	11.02.07	MM	ROC	YVM/MD	UPDATES
8	11.02.07	MM	ROC	YVM/MD	UPDATES
9	11.02.07	MM	ROC	YVM/MD	UPDATES
10	11.02.07	MM	ROC	YVM/MD	UPDATES
11	11.02.07	MM	ROC	YVM/MD	UPDATES
12	11.02.07	MM	ROC	YVM/MD	UPDATES
13	11.02.07	MM	ROC	YVM/MD	UPDATES
14	11.02.07	MM	ROC	YVM/MD	UPDATES
15	11.02.07	MM	ROC	YVM/MD	UPDATES
16	11.02.07	MM	ROC	YVM/MD	UPDATES
17	11.02.07	MM	ROC	YVM/MD	UPDATES
18	11.02.07	MM	ROC	YVM/MD	UPDATES
19	11.02.07	MM	ROC	YVM/MD	UPDATES
20	11.02.07	MM	ROC	YVM/MD	UPDATES
21	11.02.07	MM	ROC	YVM/MD	UPDATES
22	11.02.07	MM	ROC	YVM/MD	UPDATES
23	11.02.07	MM	ROC	YVM/MD	UPDATES
24	11.02.07	MM	ROC	YVM/MD	UPDATES
25	11.02.07	MM	ROC	YVM/MD	UPDATES
26	11.02.07	MM	ROC	YVM/MD	UPDATES
27	11.02.07	MM	ROC	YVM/MD	UPDATES
28	11.02.07	MM	ROC	YVM/MD	UPDATES
29	11.02.07	MM	ROC	YVM/MD	UPDATES
30	11.02.07	MM	ROC	YVM/MD	UPDATES
31	11.02.07	MM	ROC	YVM/MD	UPDATES
32	11.02.07	MM	ROC	YVM/MD	UPDATES
33	11.02.07	MM	ROC	YVM/MD	UPDATES
34	11.02.07	MM	ROC	YVM/MD	UPDATES
35	11.02.07	MM	ROC	YVM/MD	UPDATES
36	11.02.07	MM	ROC	YVM/MD	UPDATES
37	11.02.07	MM	ROC	YVM/MD	UPDATES
38	11.02.07	MM	ROC	YVM/MD	UPDATES
39	11.02.07	MM	ROC	YVM/MD	UPDATES
40	11.02.07	MM	ROC	YVM/MD	UPDATES
41	11.02.07	MM	ROC	YVM/MD	UPDATES
42	11.02.07	MM	ROC	YVM/MD	UPDATES
43	11.02.07	MM	ROC	YVM/MD	UPDATES
44	11.02.07	MM	ROC	YVM/MD	UPDATES
45	11.02.07	MM	ROC	YVM/MD	UPDATES
46	11.02.07	MM	ROC	YVM/MD	UPDATES
47	11.02.07	MM	ROC	YVM/MD	UPDATES
48	11.02.07	MM	ROC	YVM/MD	UPDATES
49	11.02.07	MM	ROC	YVM/MD	UPDATES
50	11.02.07	MM	ROC	YVM/MD	UPDATES

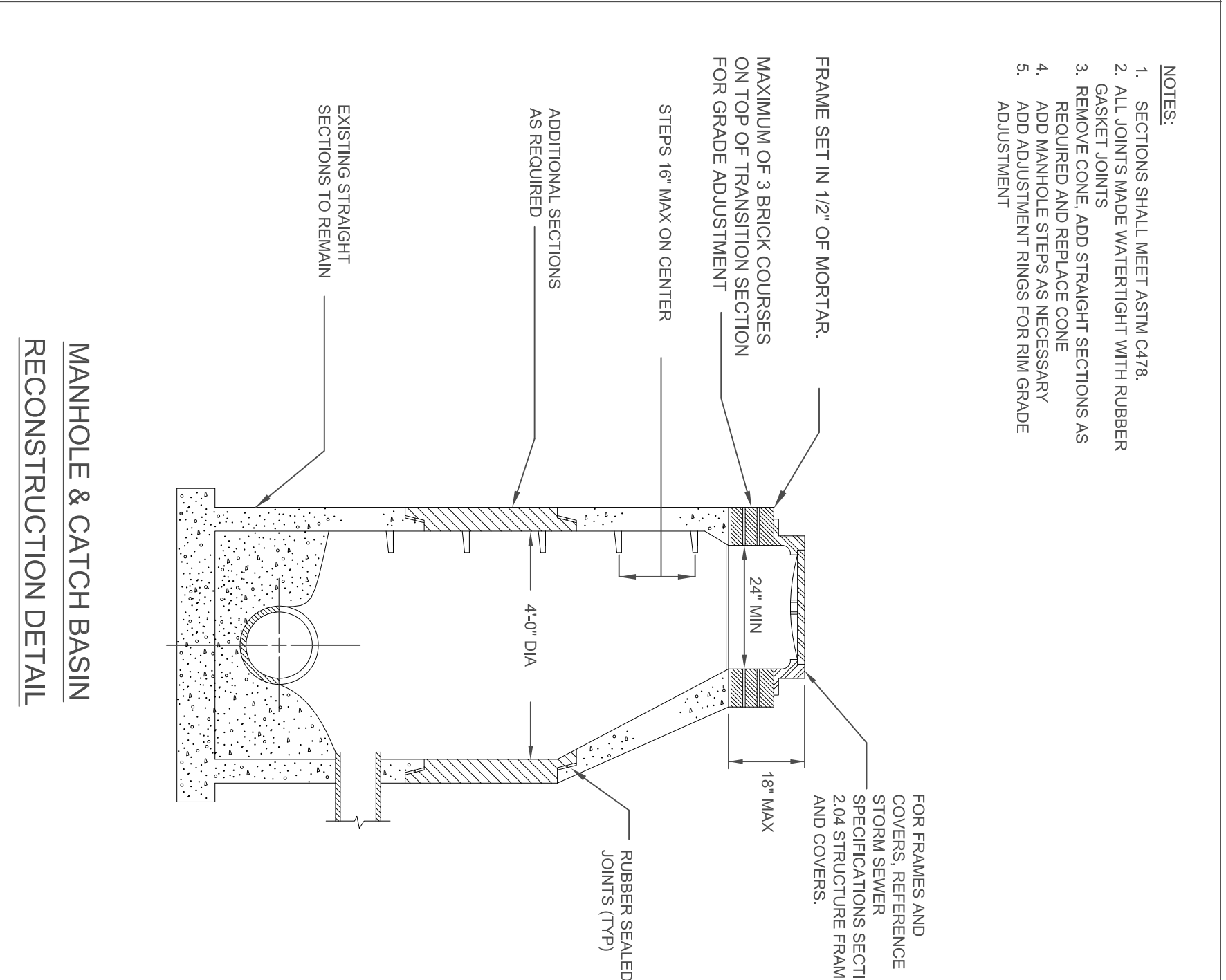
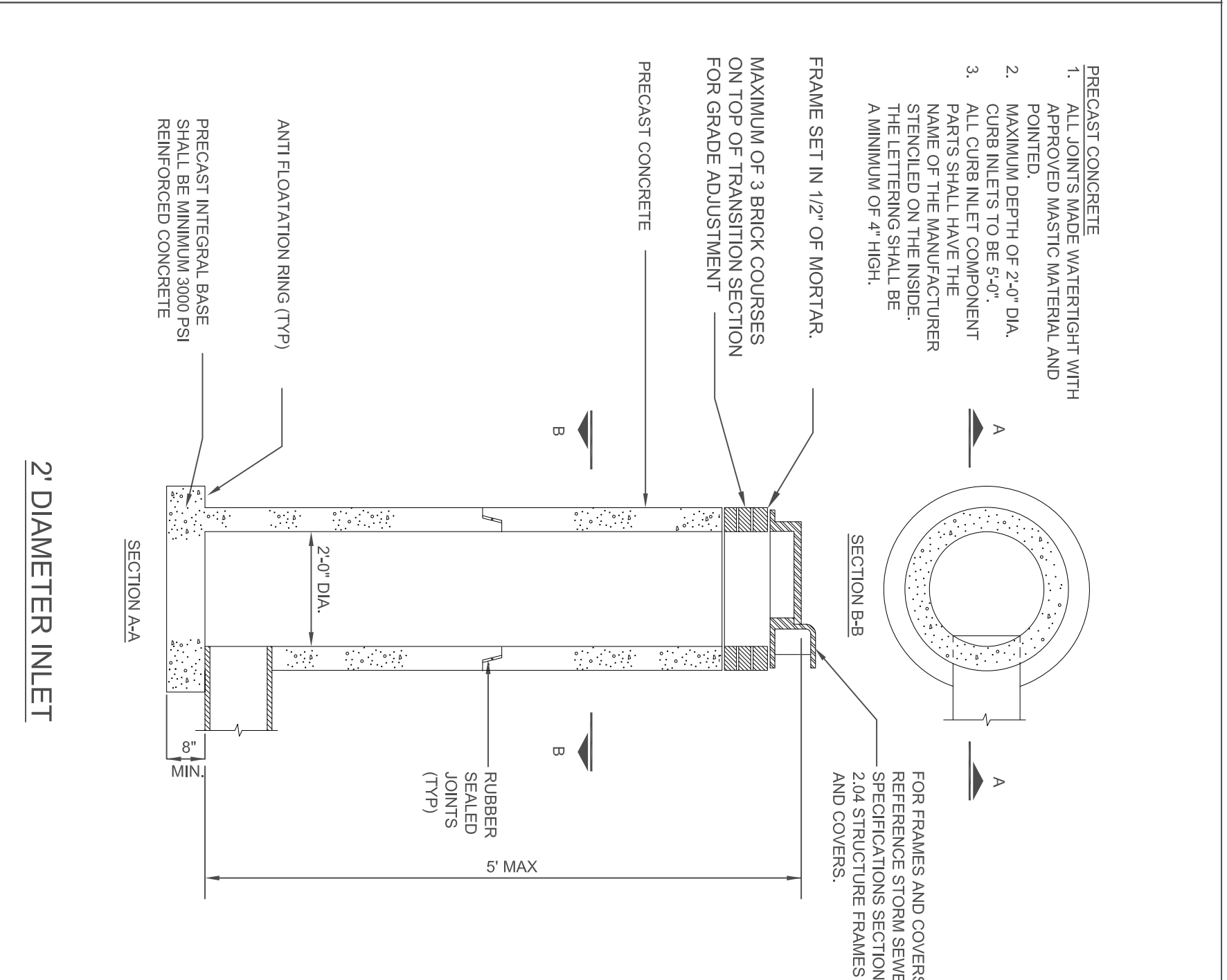
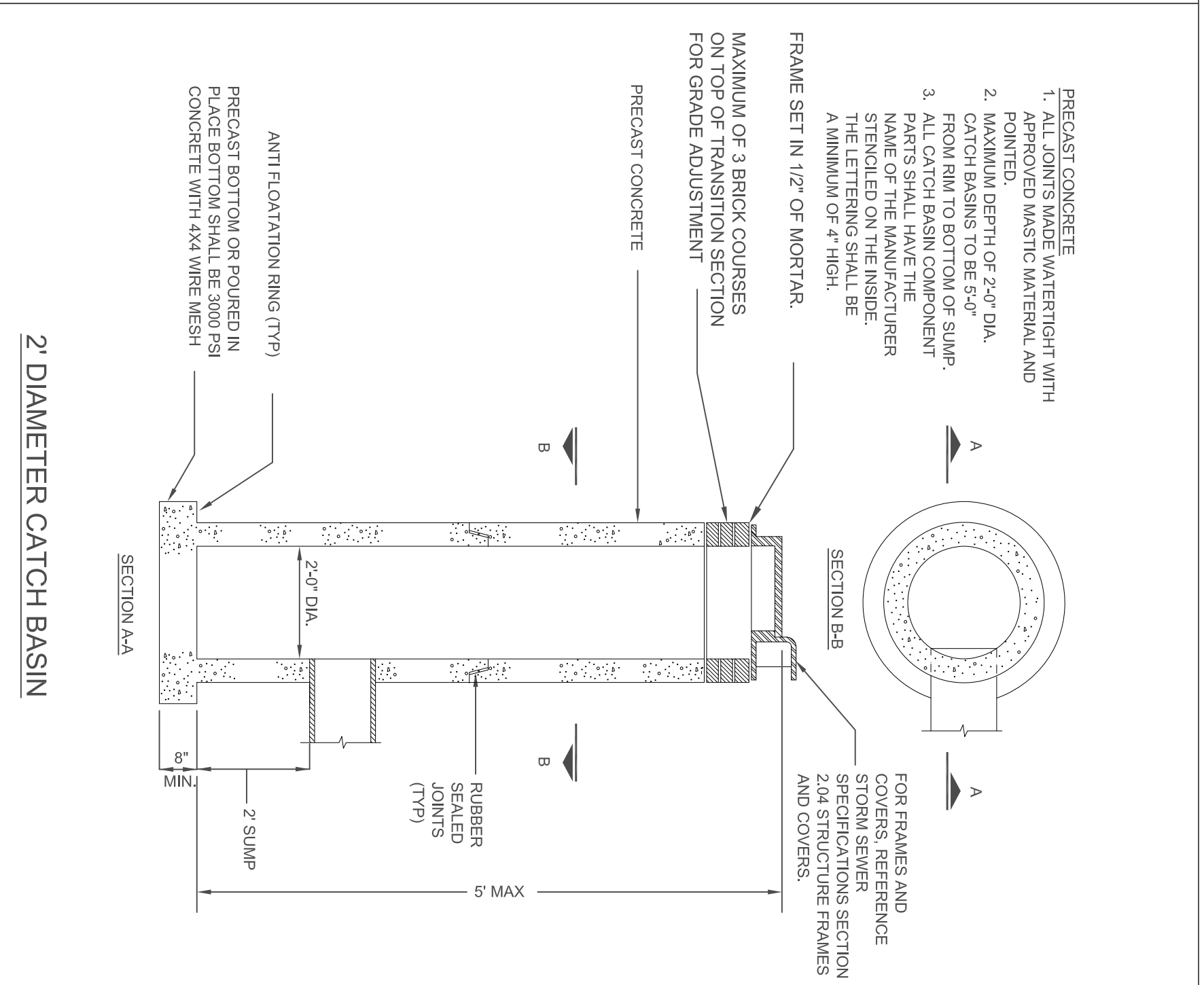

DIA	A	B	C	D	E	F	G
12"	5"	13"	45.5"	72"	24"	2"	2"
15"	7"	16"	43.5"	72"	30"	2.25"	2.25"
18"	11"	19"	41.5"	72"	36"	2.5"	2.5"
24"	12"	25"	29"	72"	48"	3"	2"
30"	14"	31"	19"	72"	60"	3.5"	3.5"
36"	17"	37"	34.5"	96"	72"	4"	4"
42"	22"	43"	32.5"	96"	78"	4.5"	4.5"
48"	24"	49"	23.5"	96"	84"	5"	5"

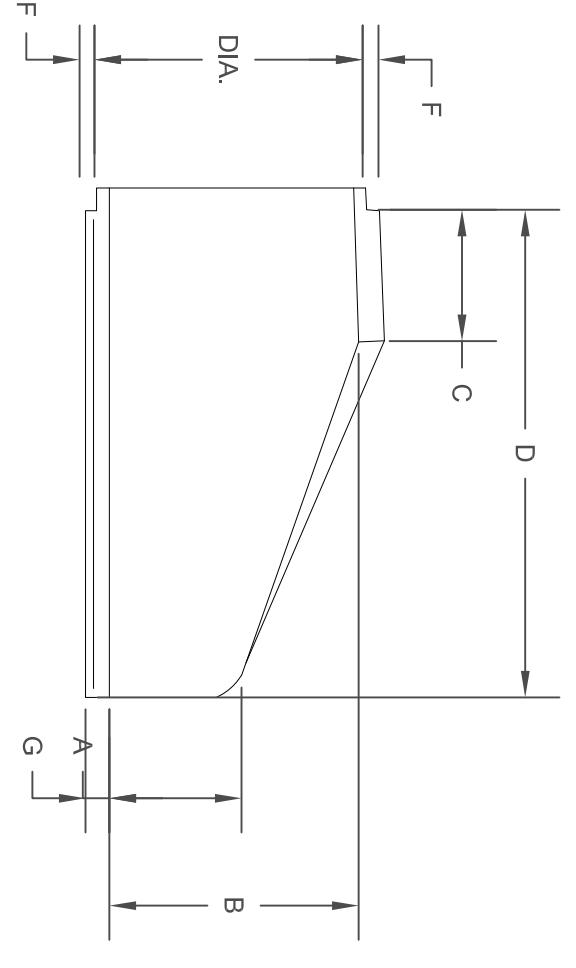

NOTE:
 FLARED END SECTIONS SHALL BE MANUFACTURED TO THE CLASS SPECIFICATIONS AS THE PIPE ITSELF.

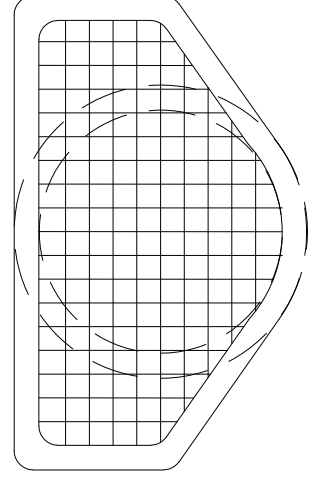

STANDARD END SECTIONS FOR PRECAST CONCRETE

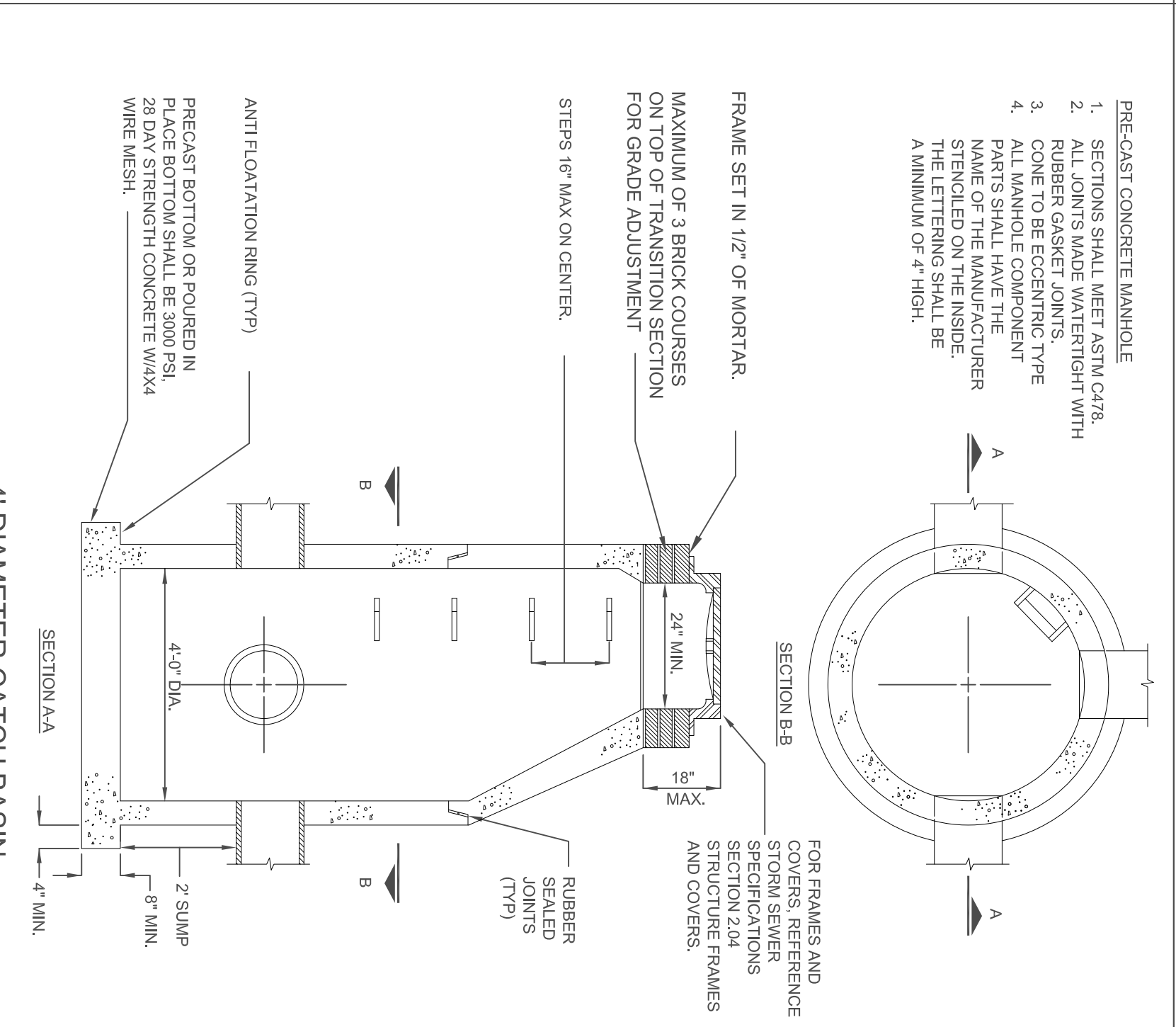
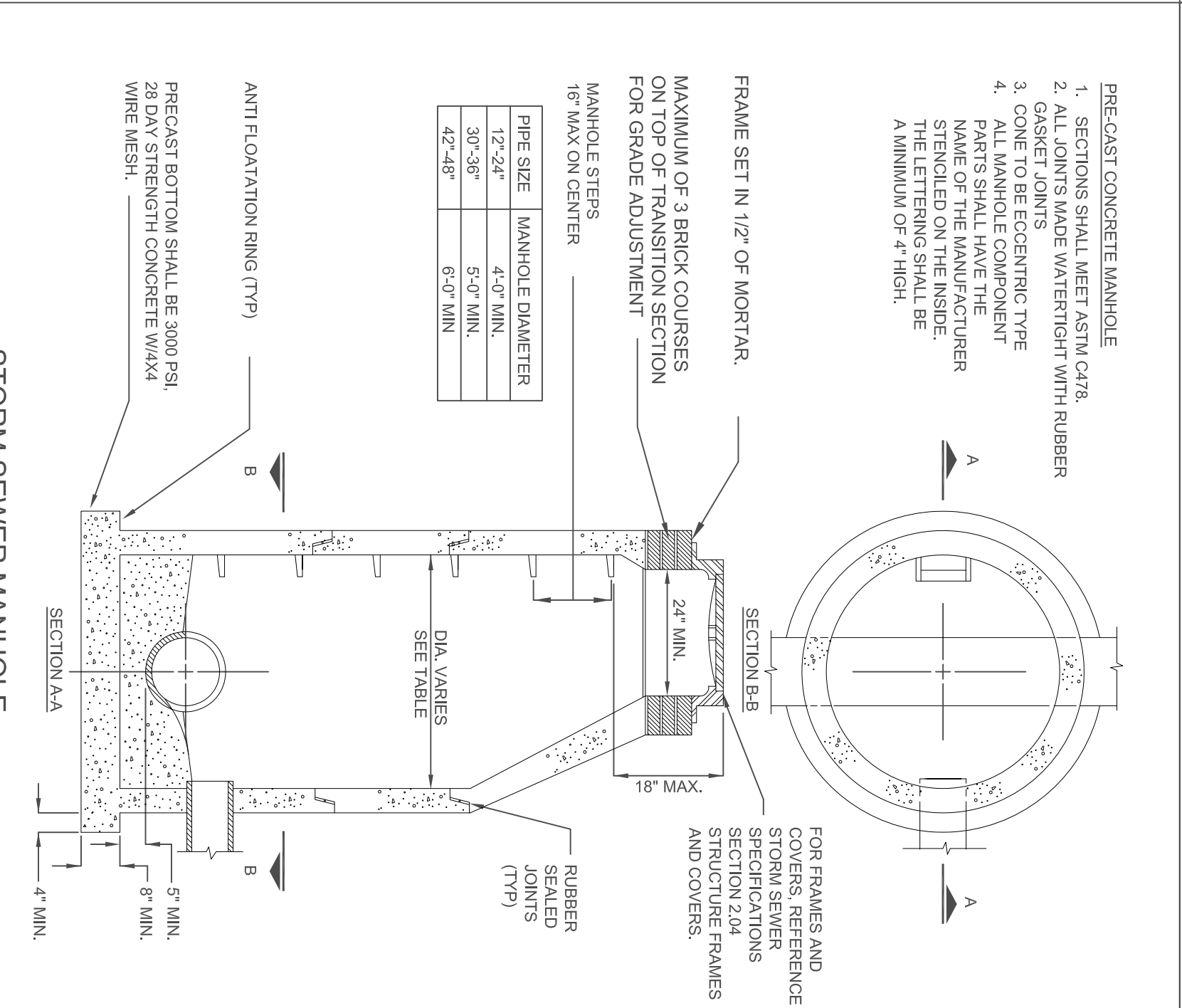
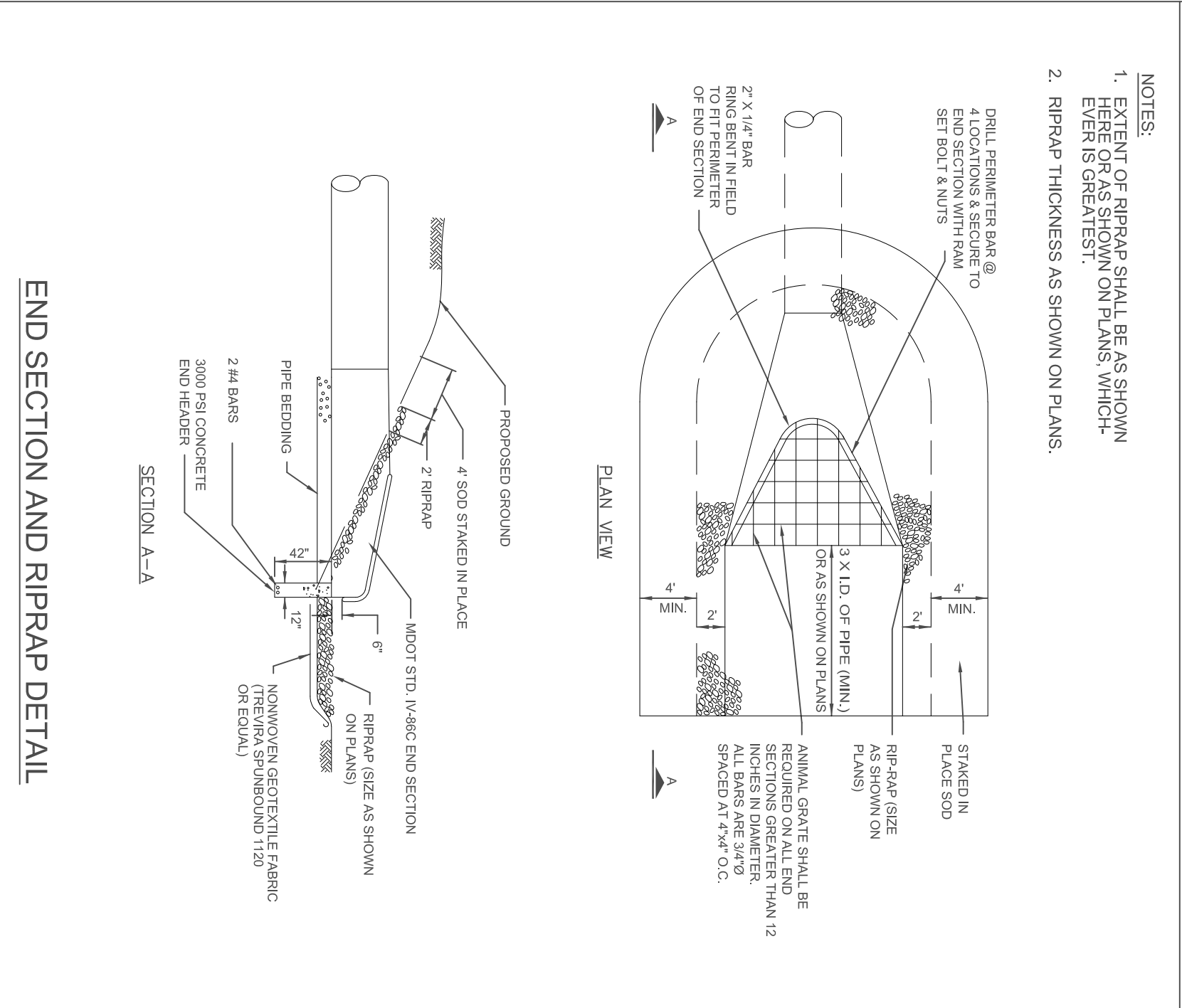

STORM SEWER DETAILS

Client/Project
 ANN ARBOR TOWNSHIP
 Standard Specifications and Details