

UPDATES	SHT.	ROC.	DATE	BY	APPD.
UPDATES	18.03.01				
UPDATES	18.02.23				
UPDATES	17.07.14				
UPDATES	13.01.17				
Revision	By	Appd.	17.04.00		

File Name:	TIN.	DWG.	DATE	BY	APPD.
W-01.DWG		11.02.07			
Permit-Stamp	Dwn.	Chkd.	Dsgn.	Y17M00	

Client/Project
ANN ARBOR TOWNSHIP

Standard Specifications and Details

Title
WATER MAIN DETAILS

Project No. Scale **NOT TO SCALE**

Drawing No. Sheet **1 of 1** Revision **0**

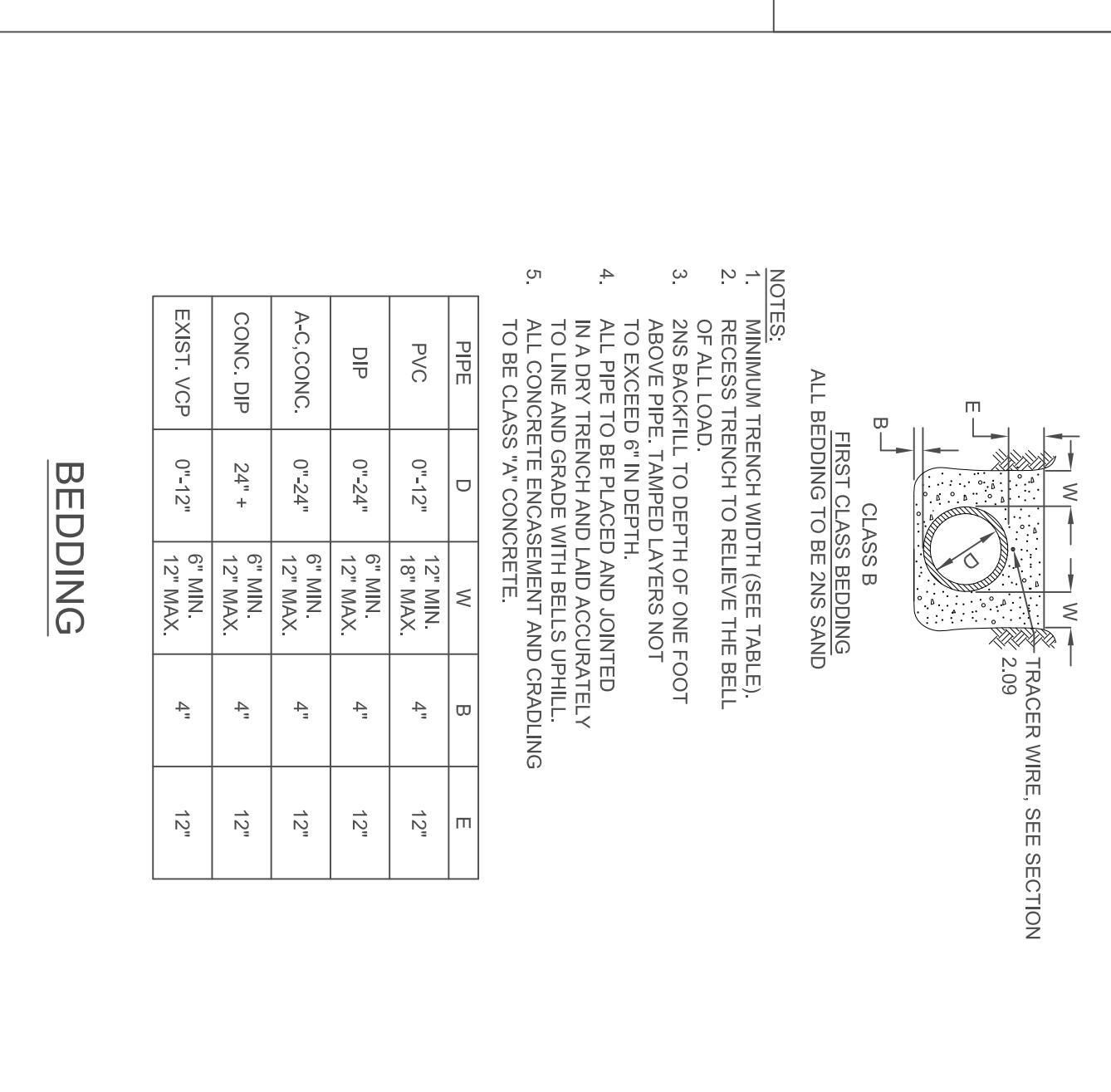
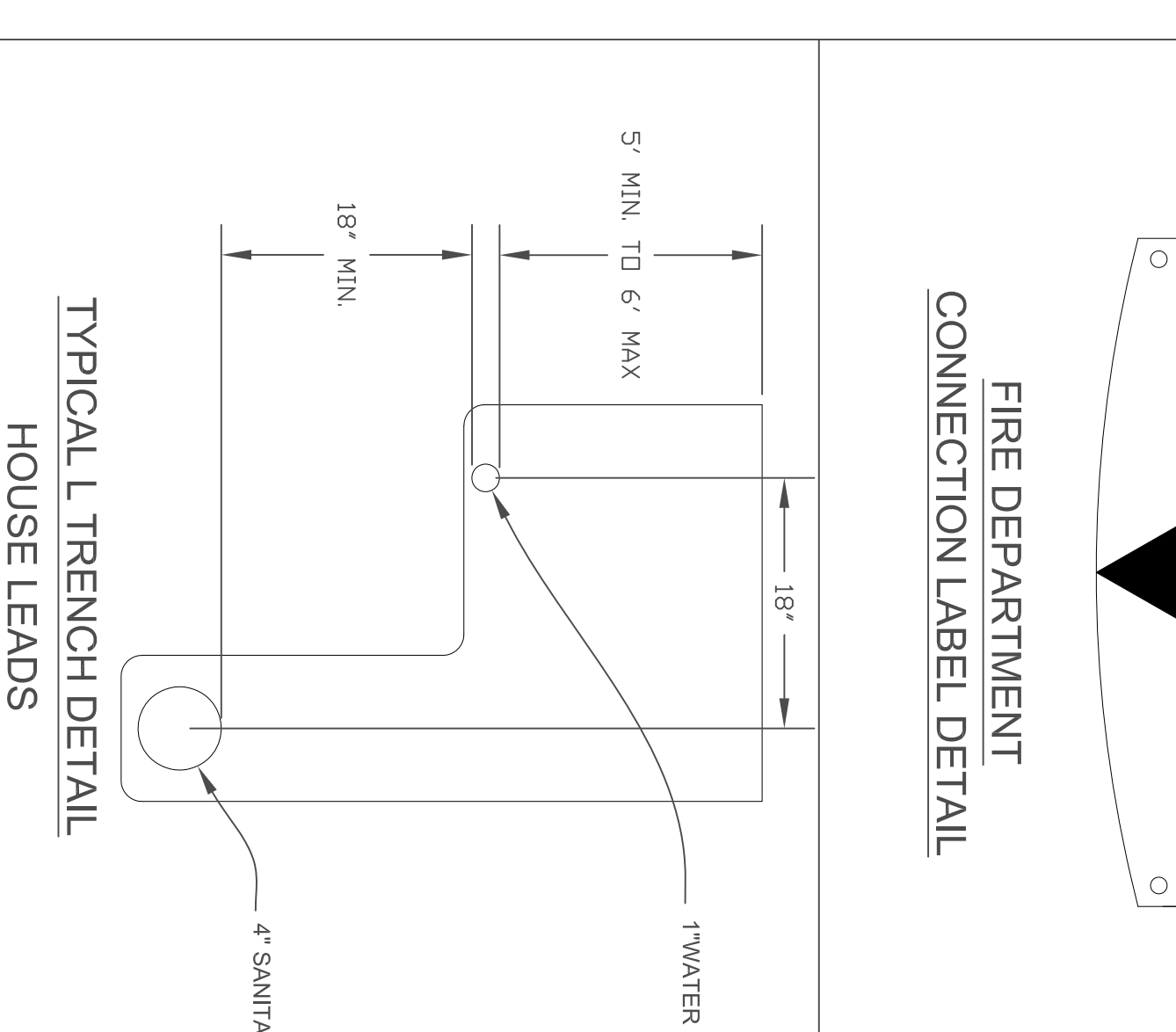
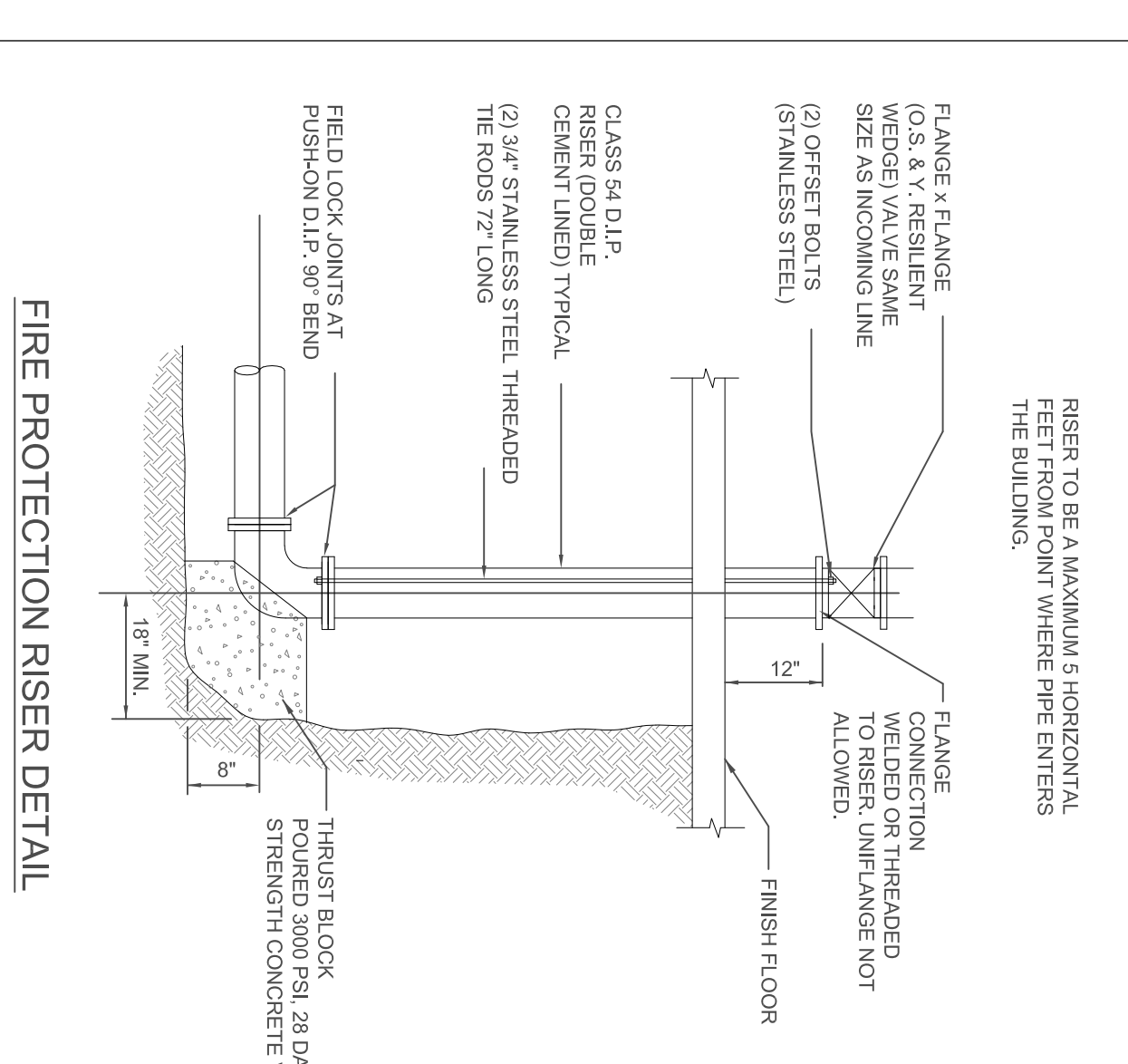
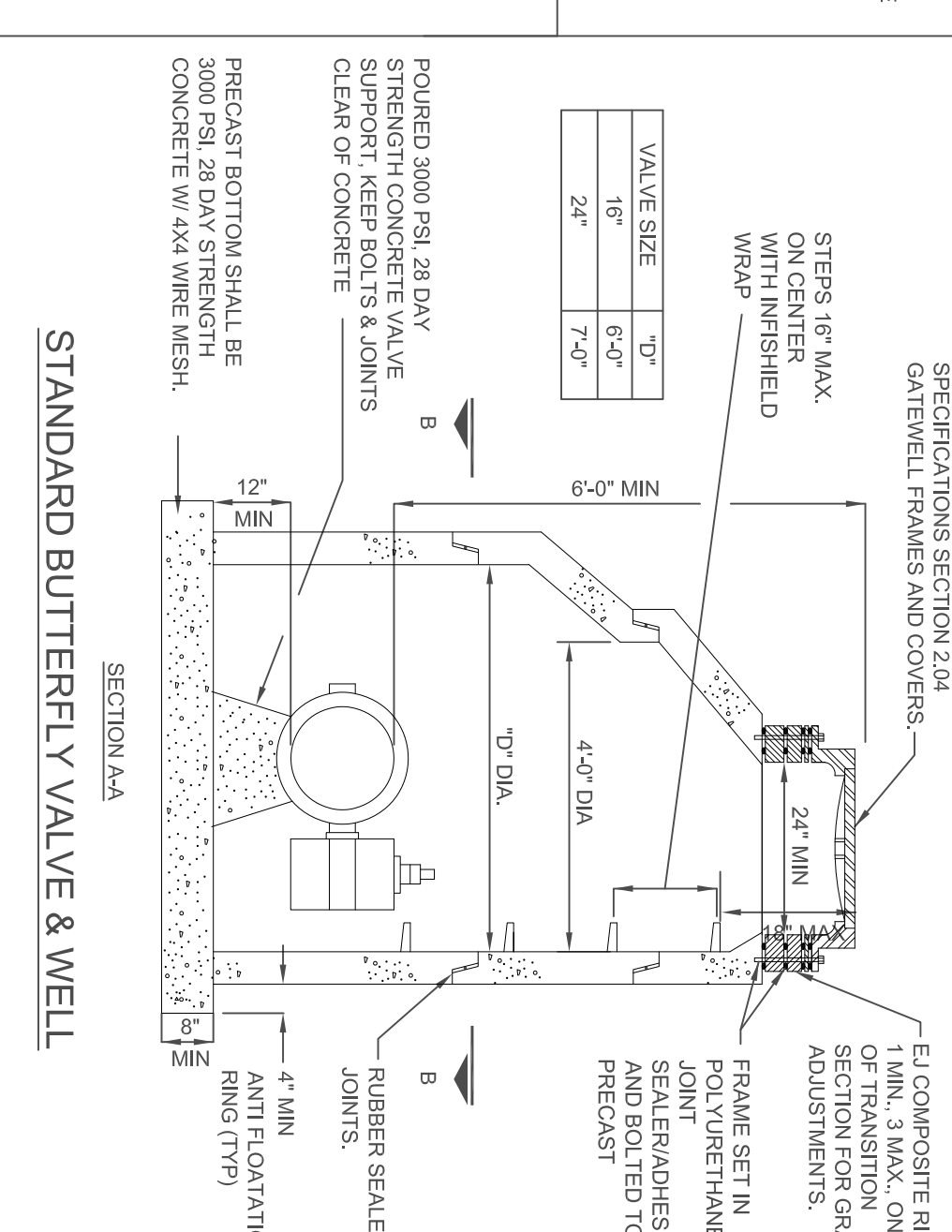
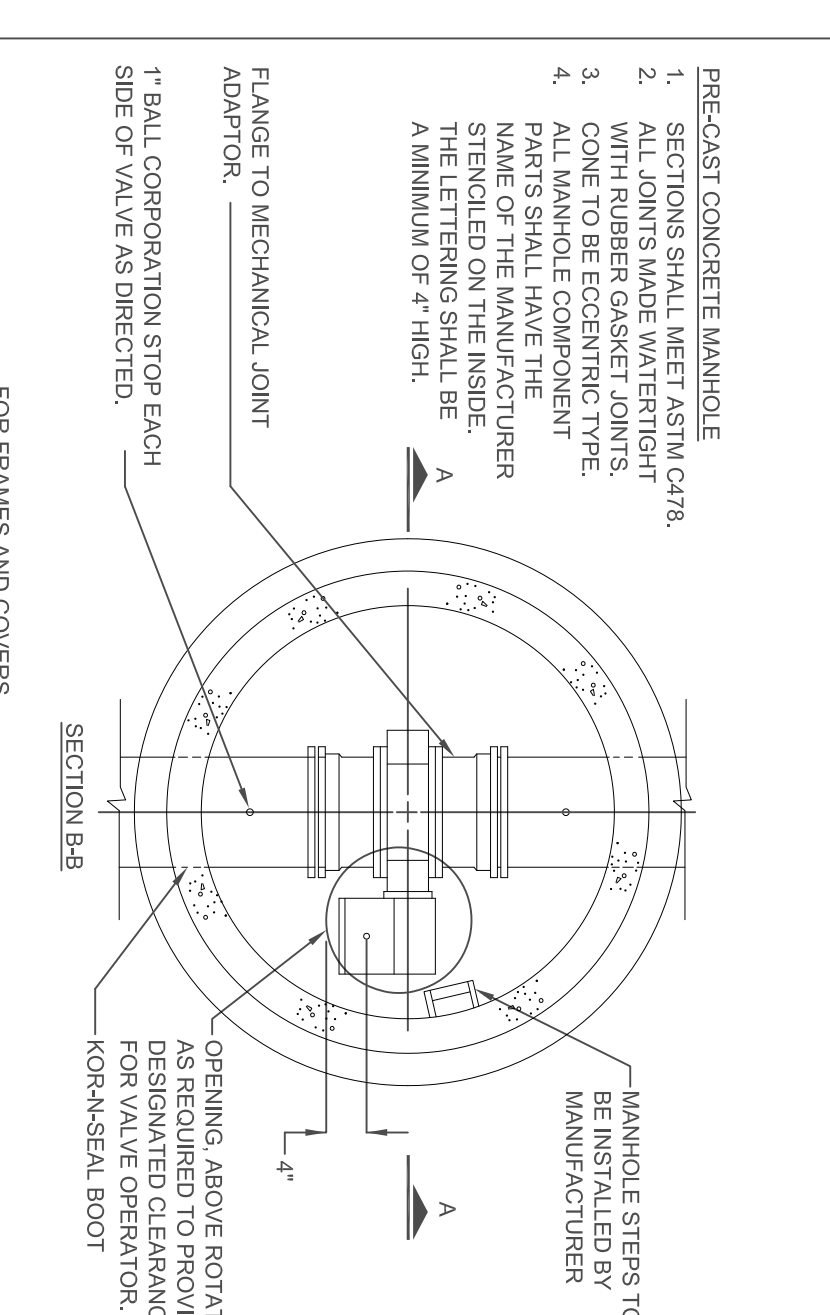
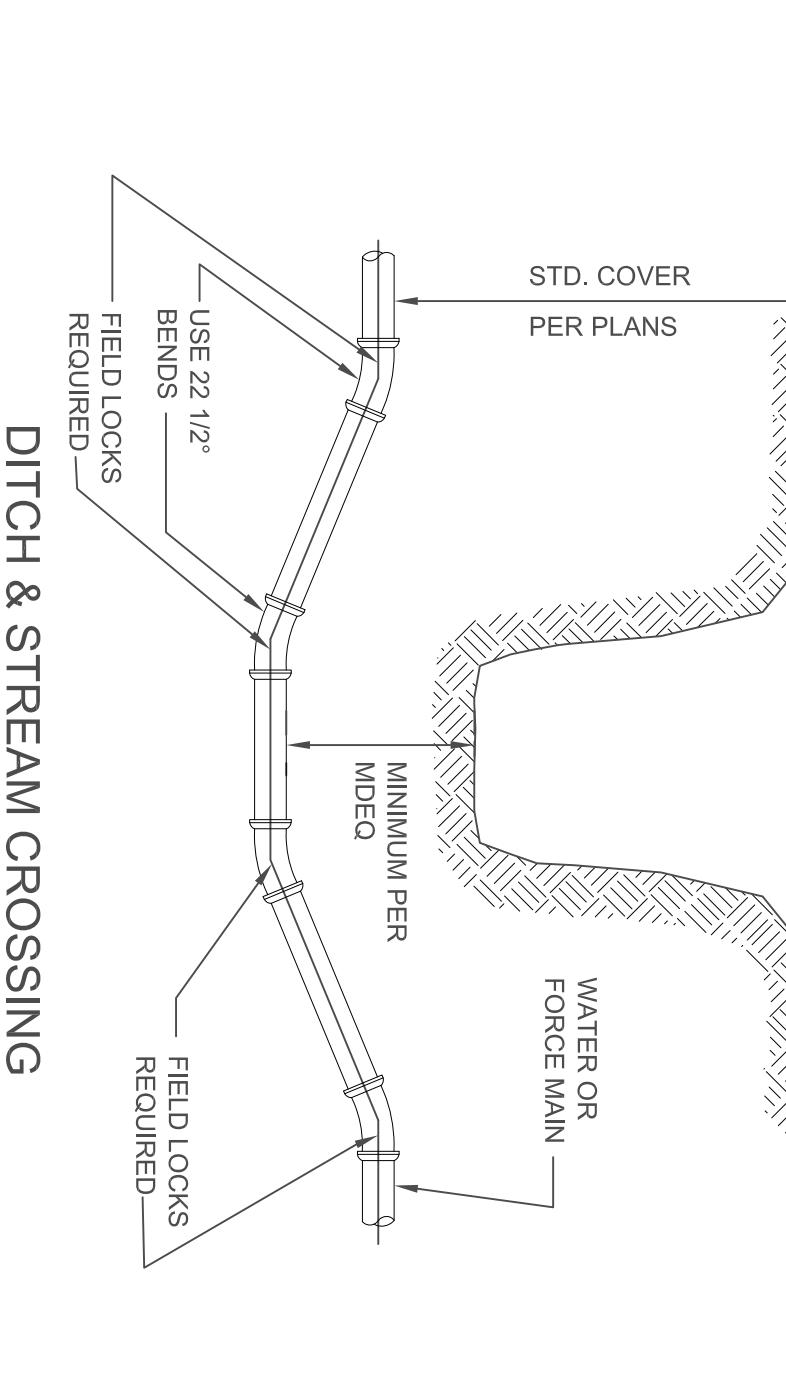
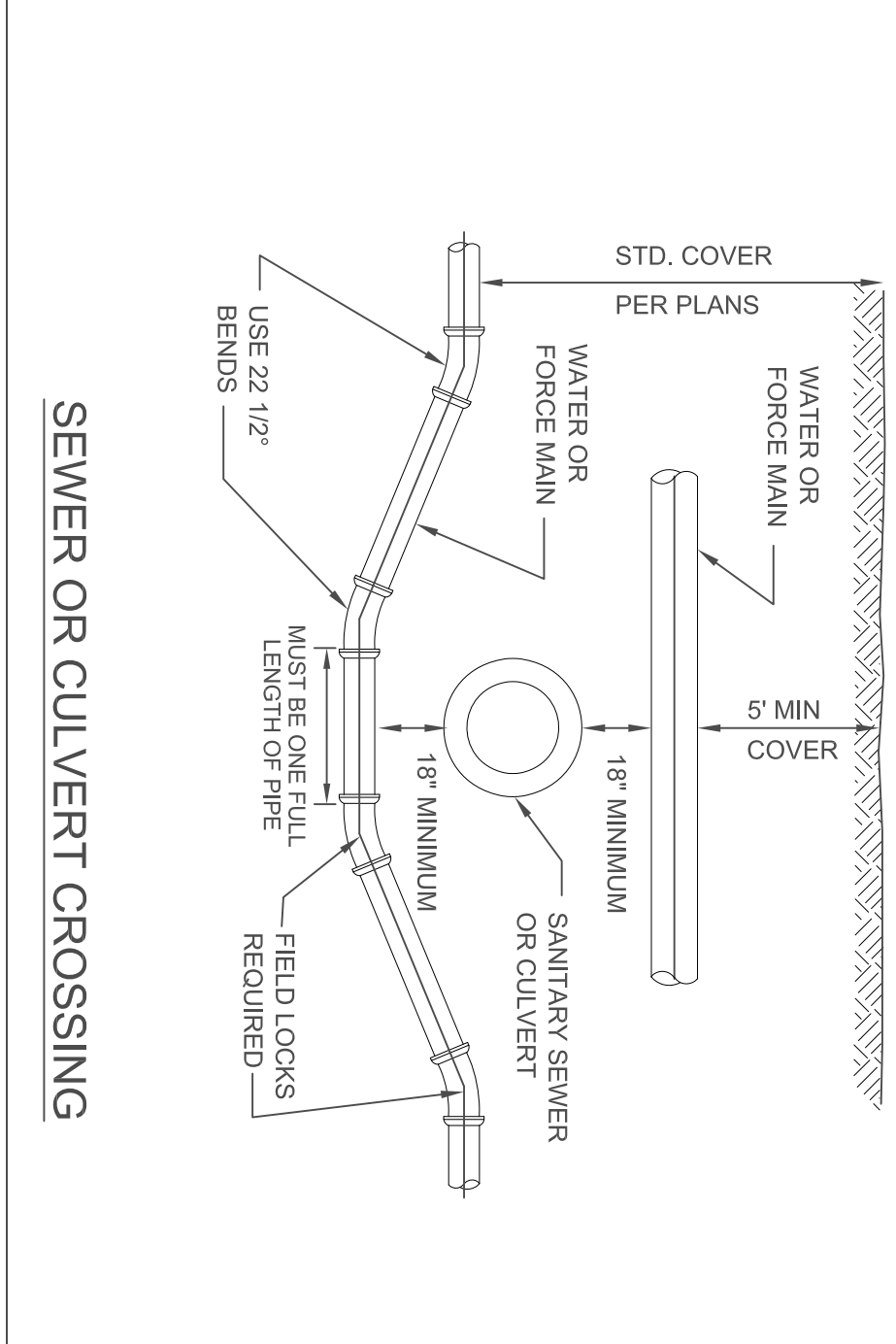
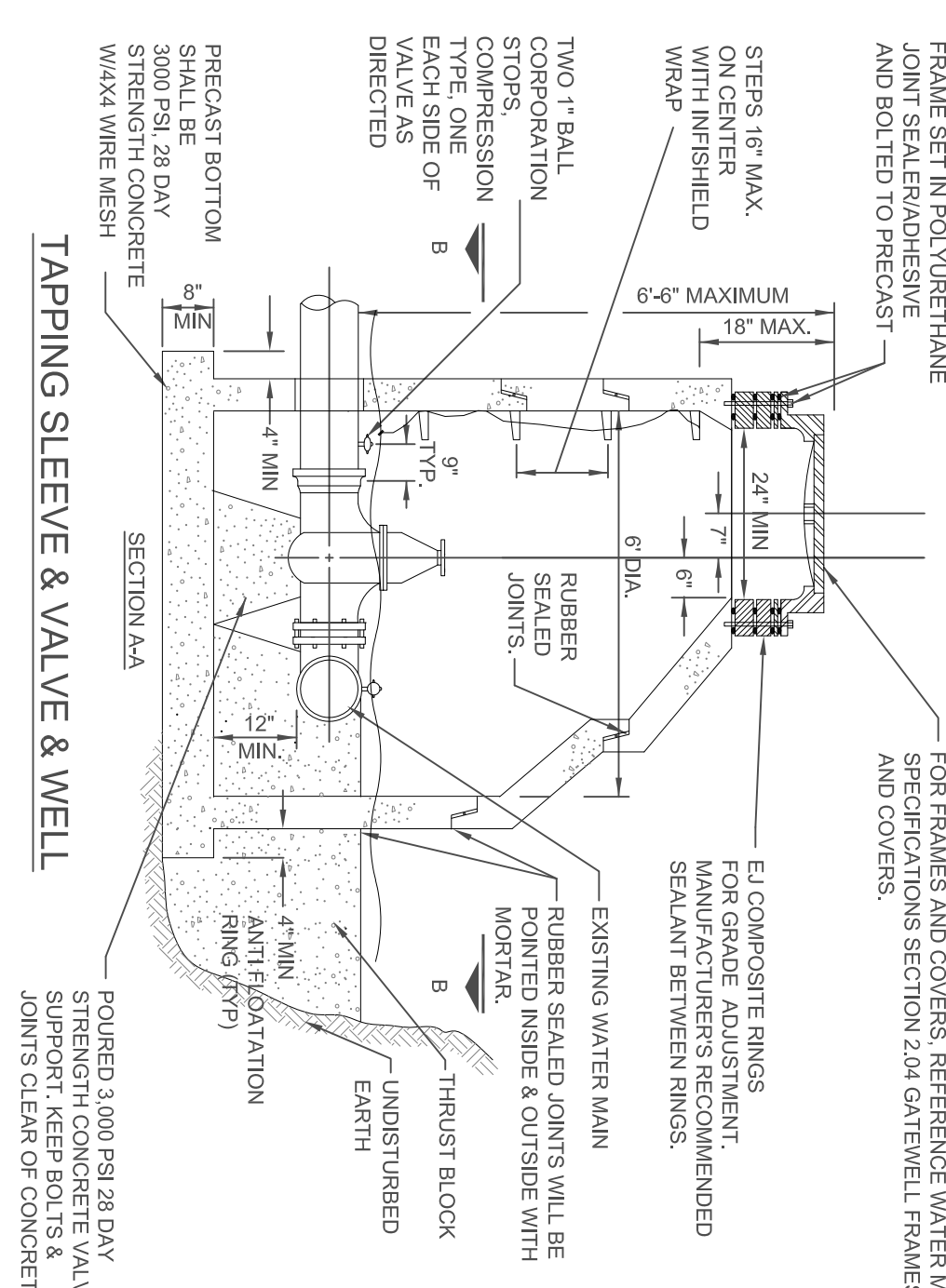
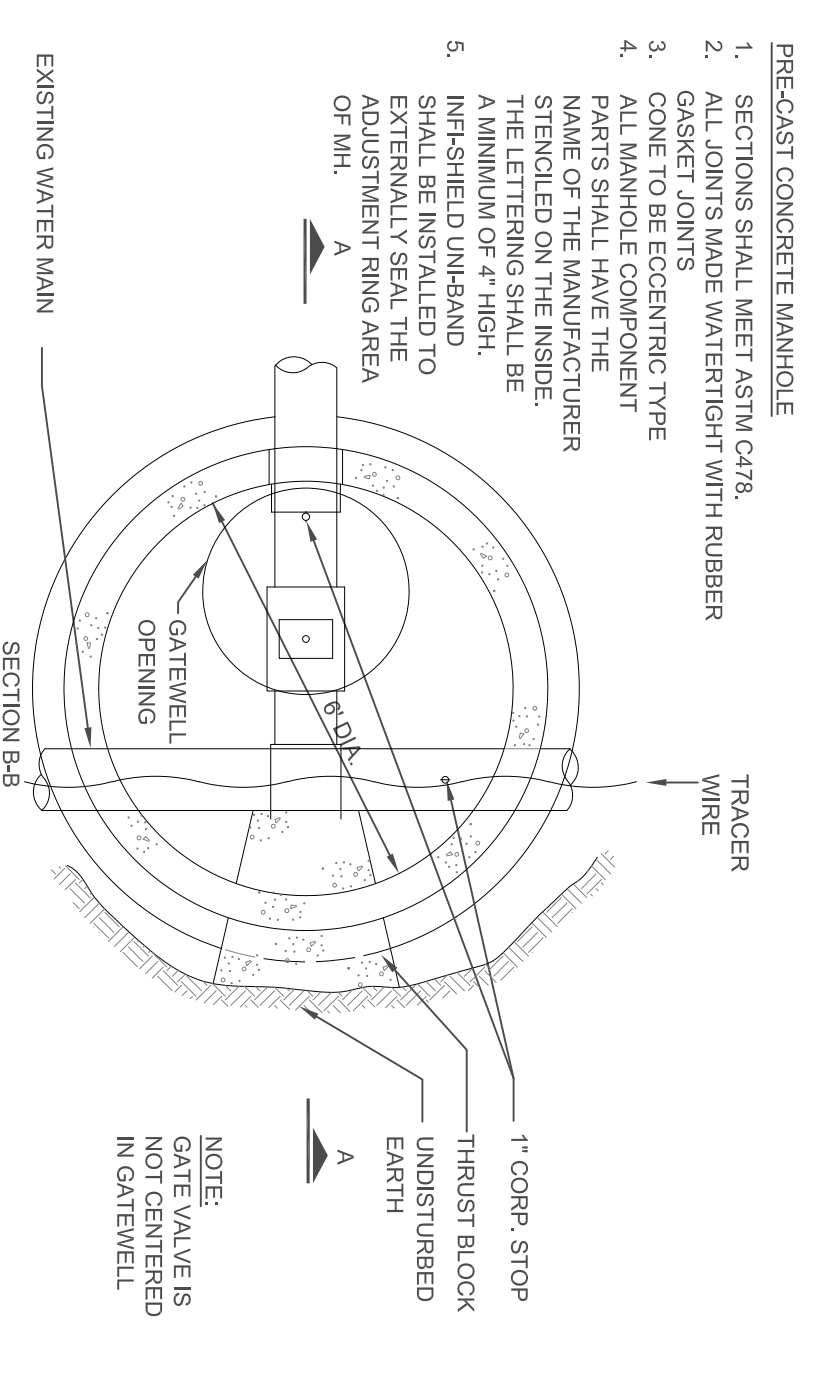
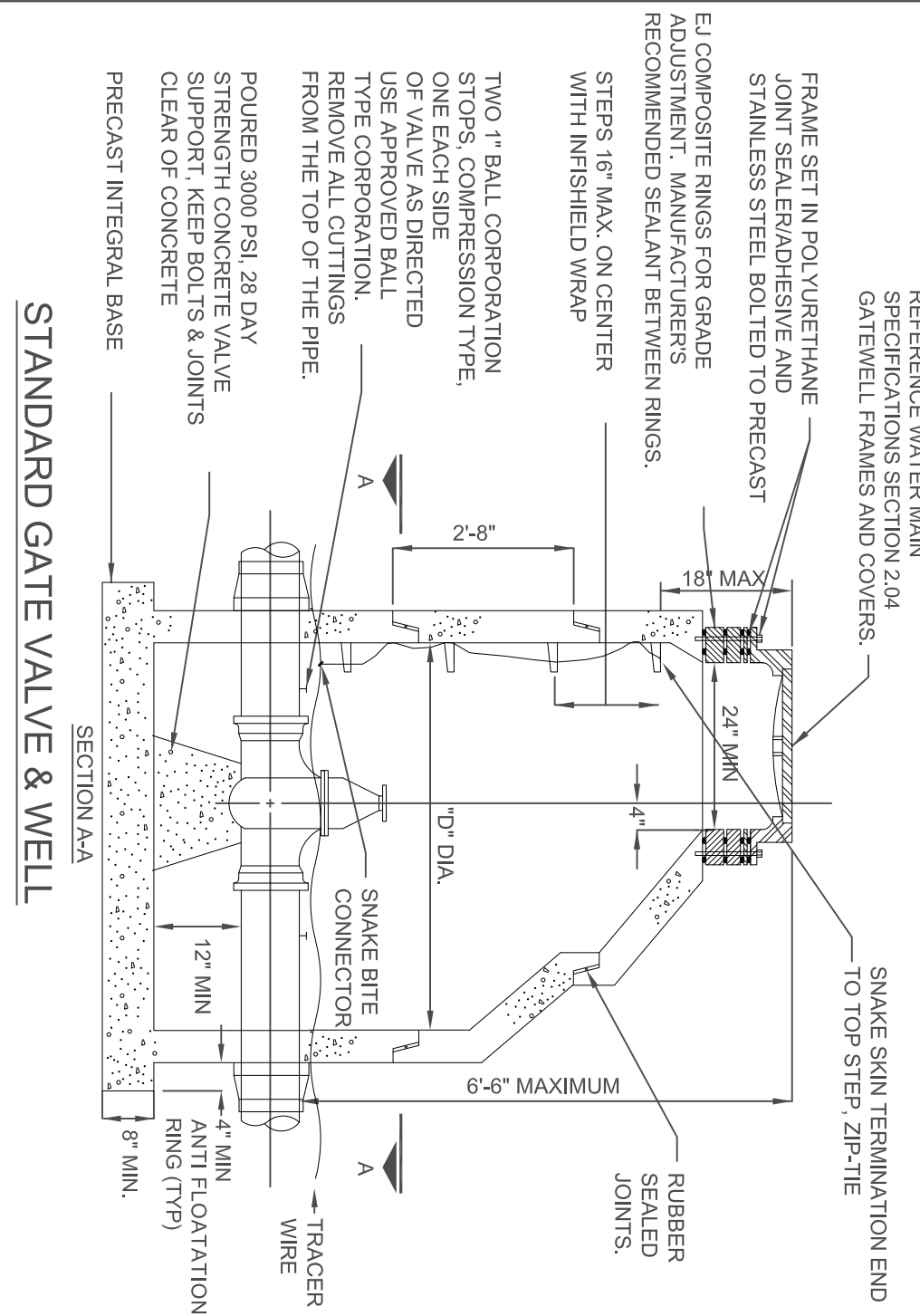
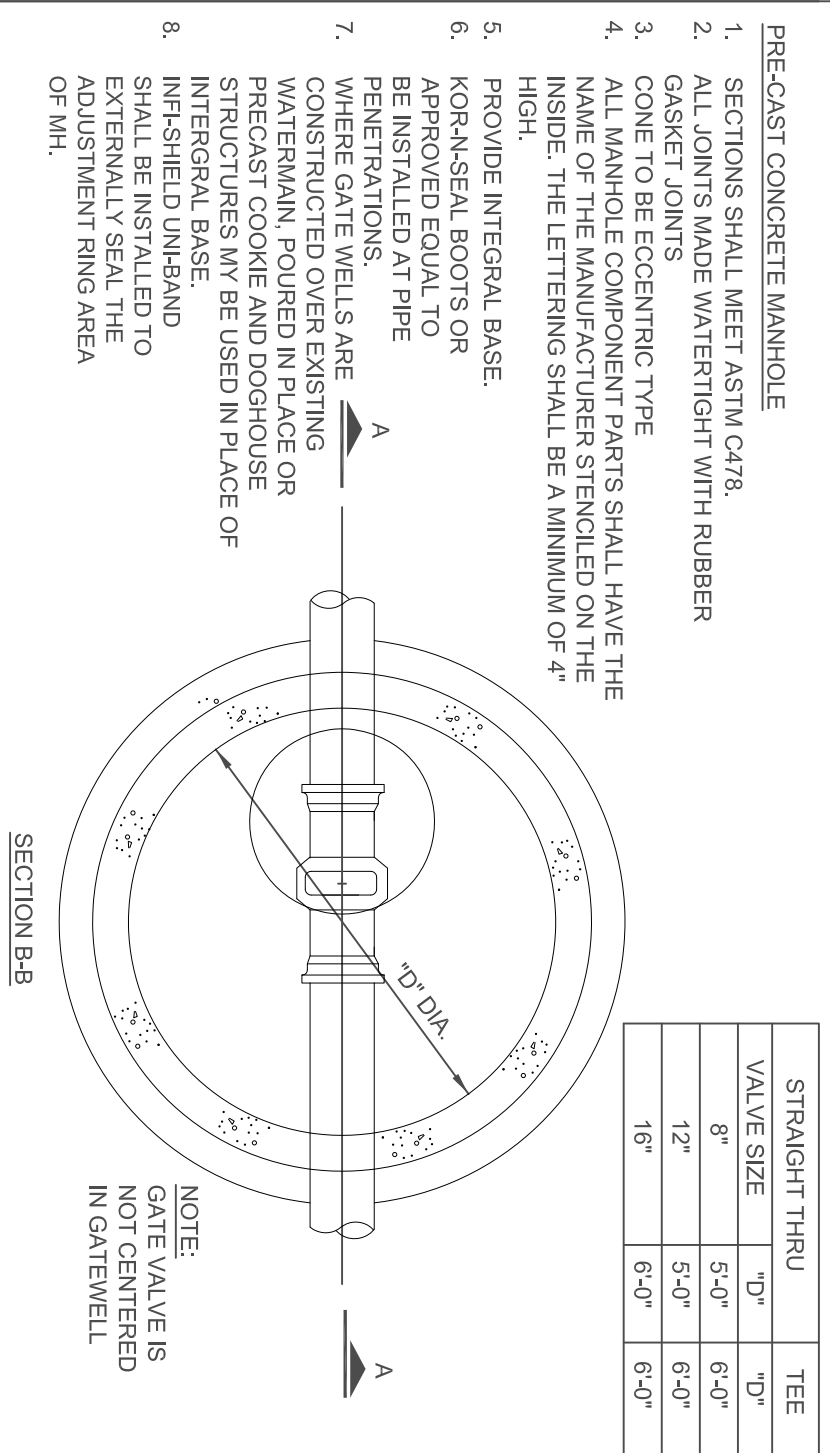

PIPE BEDDING

PIPE	D	W	B	E
PVC	0'-12"	12" MIN.	4"	12"
DIP	0'-24"	18" MIN.	4"	12"
A-C CONC.	0'-24"	6" MIN.	4"	12"
CONC. DIP	24" +	12" MIN.	4"	12"
EXIST. VCP	0'-12"	6" MIN.	4"	12"

